

BALTON®

BIII

371 200

371 220

371 300

371 320

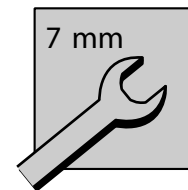
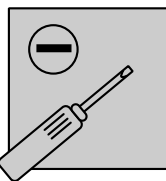
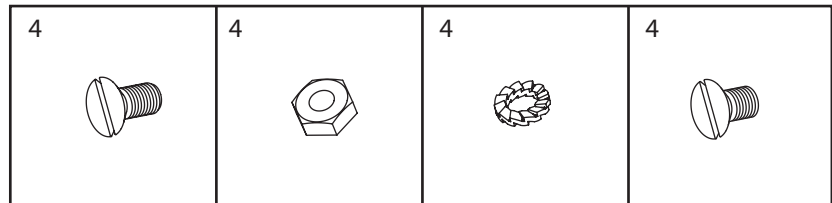
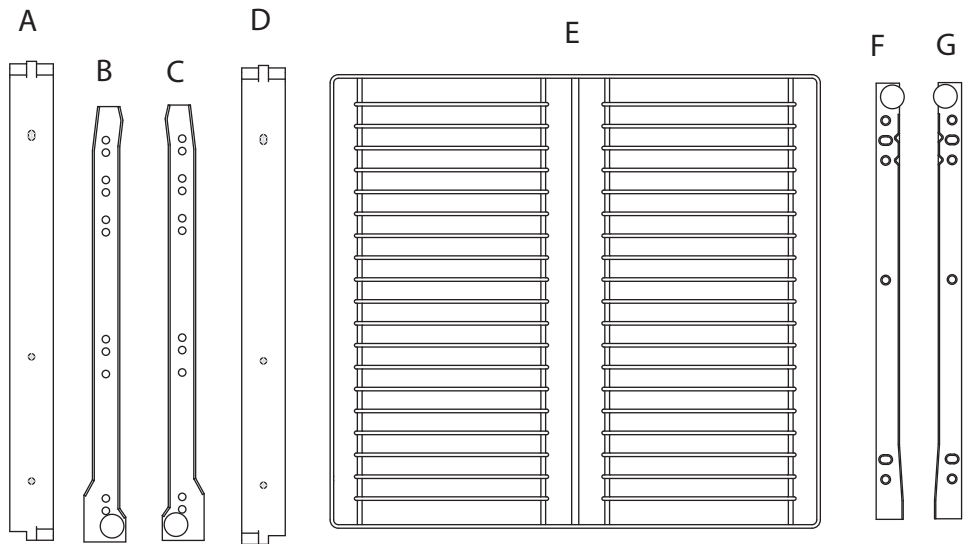
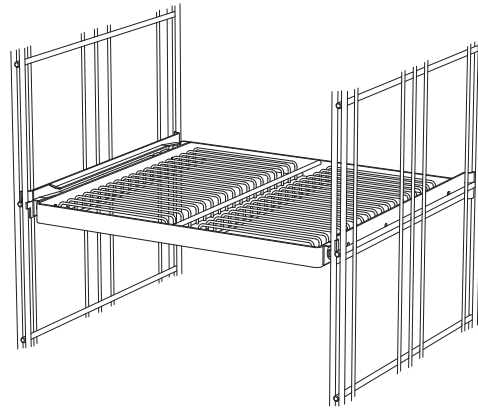

Prima del montaggio

Leggere attentamente le istruzioni del montaggio. Controllare il contenuto della confezione. Se mancano dei pezzi o sono difettosi, rivolgersi al commerciante. Assicurarsi che gli utensili di montaggio assegnati sono disponibili. Il montaggio si svolge seguendo le istruzioni passo a passo.



Before assembly

BALTON®

info@balton.se



Vor der Montage

Lesen Sie bitte als erstes die Montageanleitung sorgfältig durch. Überprüfen Sie den Verpackungsinhalt. Falls Teile fehlerhaft oder defekt sind, setzen Sie sich bitte mit Ihrem Fachhändler in Verbindung. Achten Sie darauf, dass die schraffiert dargestellten Werkzeuge bereitliegen. Die Montage erfolgt schrittweise gemäß Anleitung.



Avant le Montage

Read through the instructions carefully before starting assembly. Check the contents of the package. Contact the point of sale if you find anything defective or missing. Make sure that the shaded tools are available. Assemble step by step as shown in the instructions.

Lisez attentivement les instructions avant de commencer les travaux de montage. Contrôlez le contenu de l'emballage. En cas de pièces endommagées ou manquantes, contactez le point de vente. Assurez-vous que les outils nécessaires sont disponibles. Effectuez le montage étape par étape suivant les instructions.

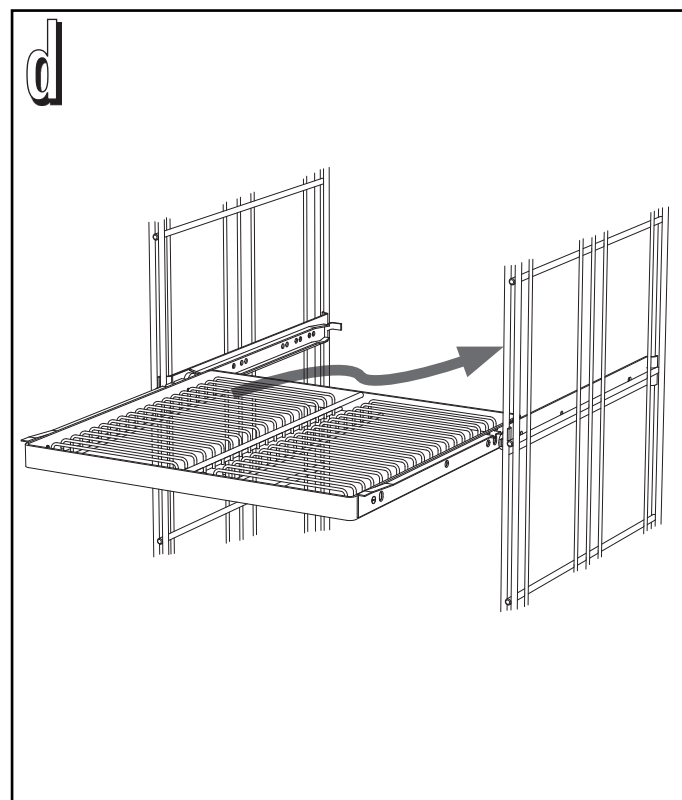
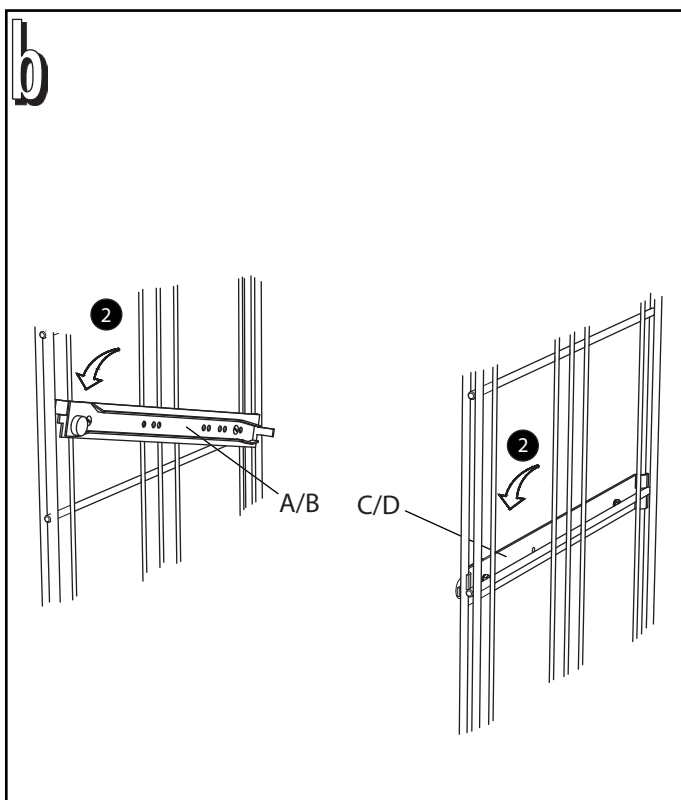
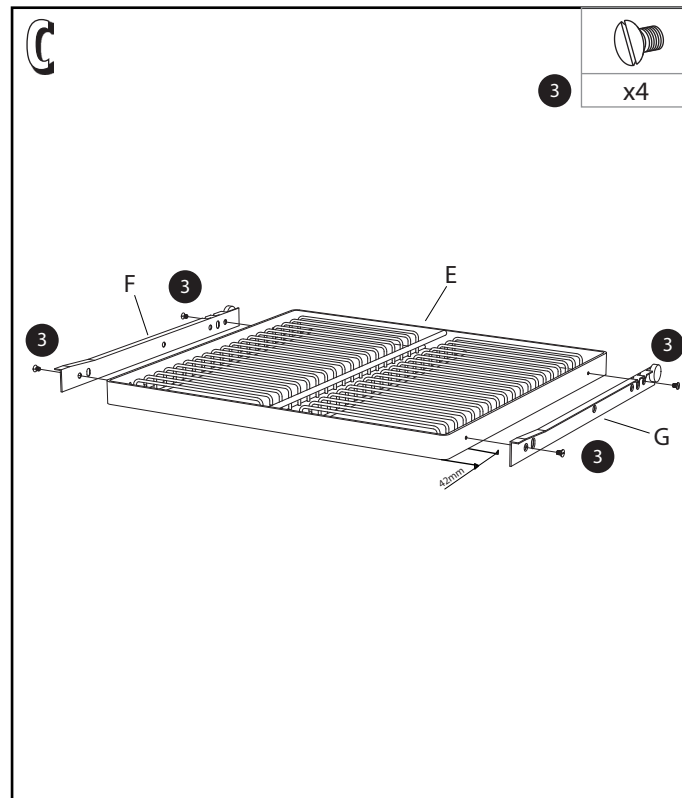
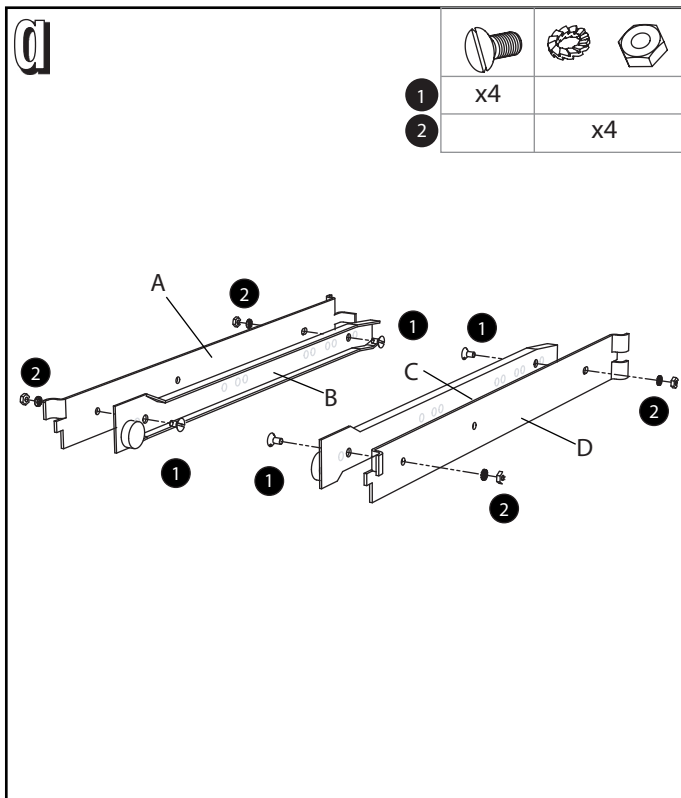

Qualche suggerimento

Circa dopo una settimana bisogna controllare e avvitare le viti e bulloni. Per la pulizia si consiglia di utilizzare solo acqua e detergente delicato. Dopo si asciuga con un panno morbido. Altri metodi di pulizia potrebbero causare i danni dei quali il produttore non risponde.



Some useful advice

You should check and re-tighten the screws and bolts a few weeks after assembly. For Cleaning, use mild soapy water only and dry with a soft cloth. Other cleaning agents may cause damage not covered by the warranty.



Noch einige gute Tips

Nach ungefähr einer Woche sollten die Schrauben und Bolzen überprüft und nachgezogen werden. Die Reinigung erfolgt nur mit Wasser und milder Seifenlauge, anschließend mit einem weichen Lappen trockenreiben. Andere Reinigungsmethoden bzw. -mittel können Schäden verursachen, für die der Hersteller nicht haftet.



Quelques bons conseils

Après quelques semaines, il convient de contrôler et de serrer à nouveau les vis et les boulons. Pour le nettoyage, utilisez de l'eau savonneuse douce. Essuyez avec un chiffon doux. D'autres méthodes de nettoyage peuvent causer des dommages non-couverts par la garantie.